

Example 3. Guildford Chimes, 1843

Ex 3. Guildford Chimes, 1843

The musical score is presented in four staves, each representing a quarter of the hour. The notation is in treble clef with a key signature of one flat (B-flat).
- **1st quarter:** A single staff containing four quarter notes: B-flat, D, F, and B-flat.
- **2nd quarter:** A single staff containing eight quarter notes: B-flat, D, F, B-flat, D, F, B-flat, and D.
- **3rd quarter:** A single staff containing sixteen quarter notes: B-flat, D, F, B-flat, D, F, B-flat, D, F, B-flat, D, F, B-flat, D, F, B-flat, and D.
- **4th quarter:** A single staff containing sixteen quarter notes. The first eight notes (B-flat, D, F, B-flat, D, F, B-flat, D) are grouped by a slur. The next eight notes (F, B-flat, D, F, B-flat, D, F, B-flat) are also grouped by a slur. The final note is a B-flat quarter note.
- **Hour strike:** A single staff containing a B-flat half note, followed by a double bar line and repeat dots, and then a B-flat quarter note.

Quarter 1 Quarter 2 Quarter 3 Quarter 4

Example 4. Magdalen Chimes, 1713

Ex. 4. Magdalen Chimes (1713)

A

1st quarter = A



2nd quarter = AB



3rd quarter = C



4th quarter = CA



Hour strike

B



Quarter 1 Quarter 2 Quarter 3 Quarter 4

Example 5. Analysis of Magdalen Chimes

Ex. 5. Analysis of Magdalen Chimes

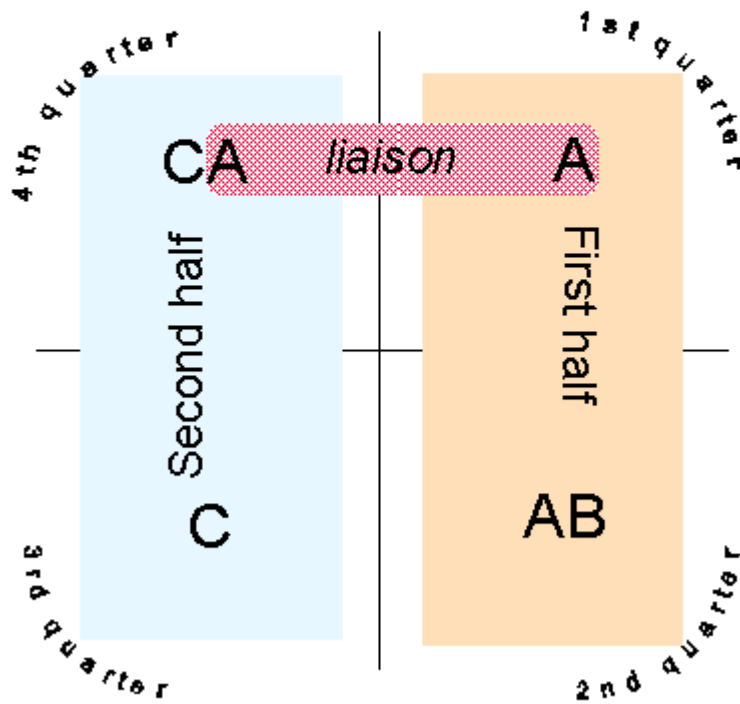

Example 7. Analysis of Westminster Quarters

Ex. 7. Analysis of Westminster Quarters

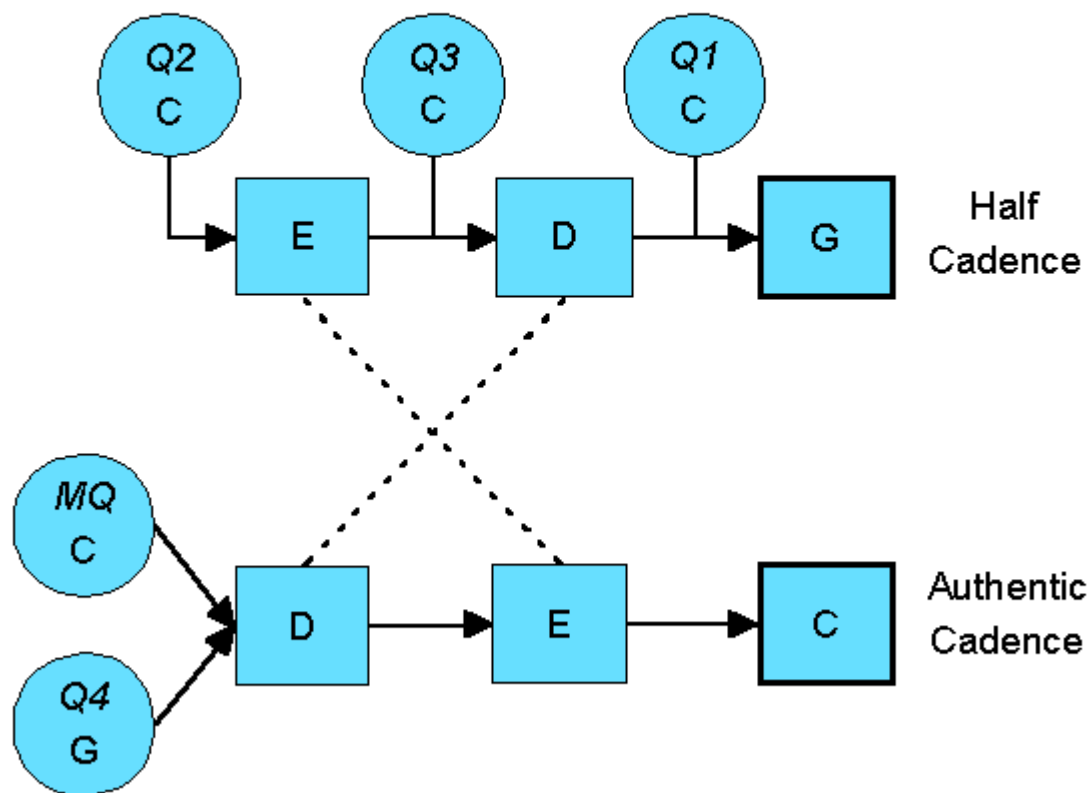

Example 9.

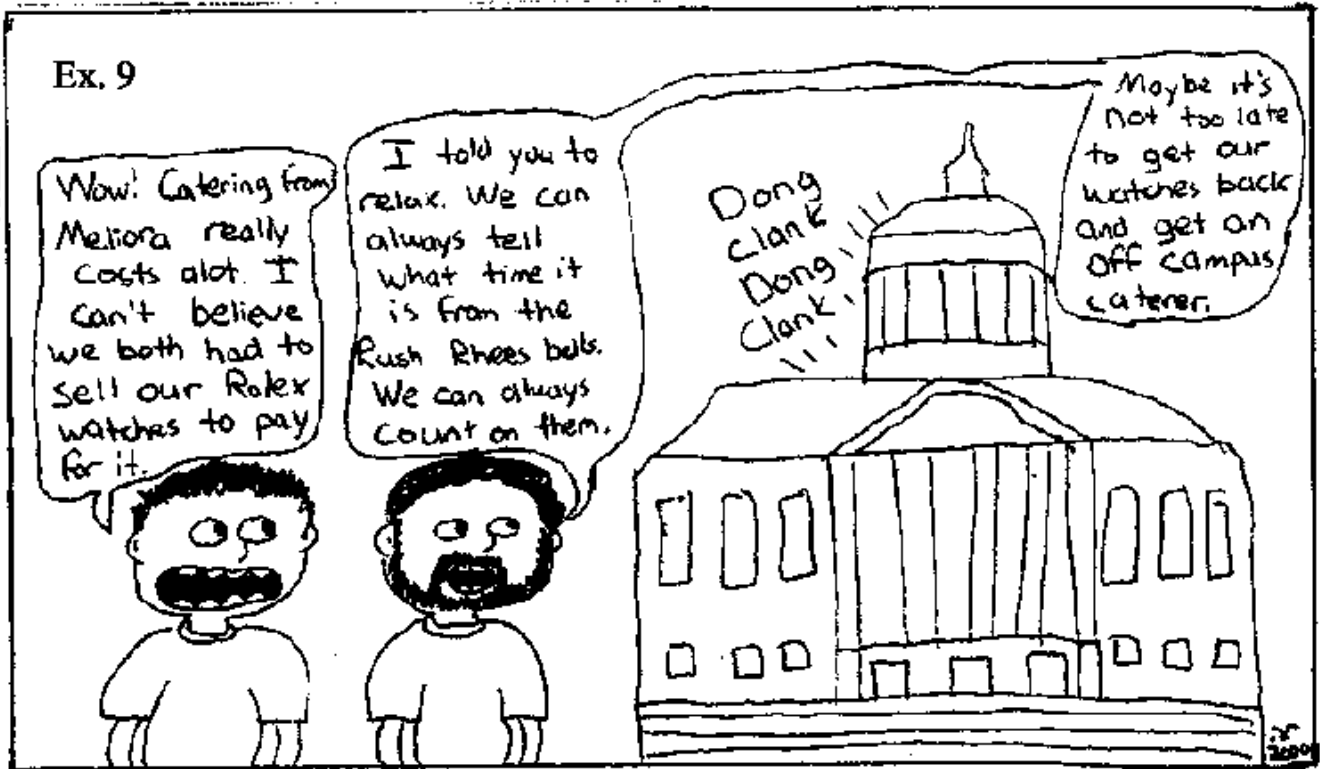

NICK RUTAR • CAMPUS TIMES STAFF