

MTO 14.1 Examples: Grant, Hysteria at the Musical Surface

(Note: audio, video, and other interactive examples are only available online)

<http://www.mtosmt.org/issues/mto.08.14.1/mto.08.14.1.grant.php>

Figure 1. Negative isography between two box-style four-node K-nets

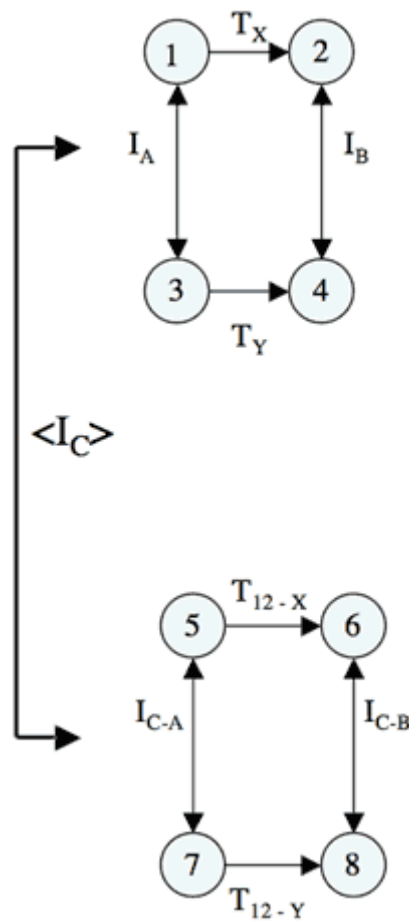

Figure 2. Inversional pairings between P&I, R&RI row-form pairs

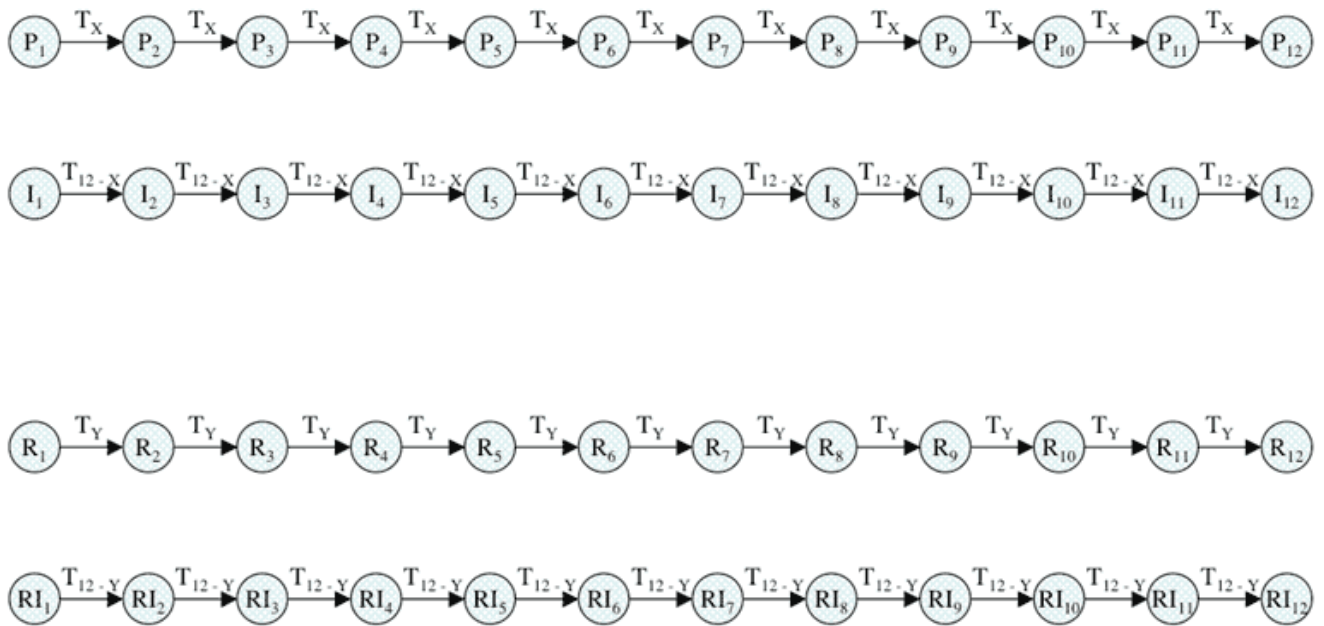
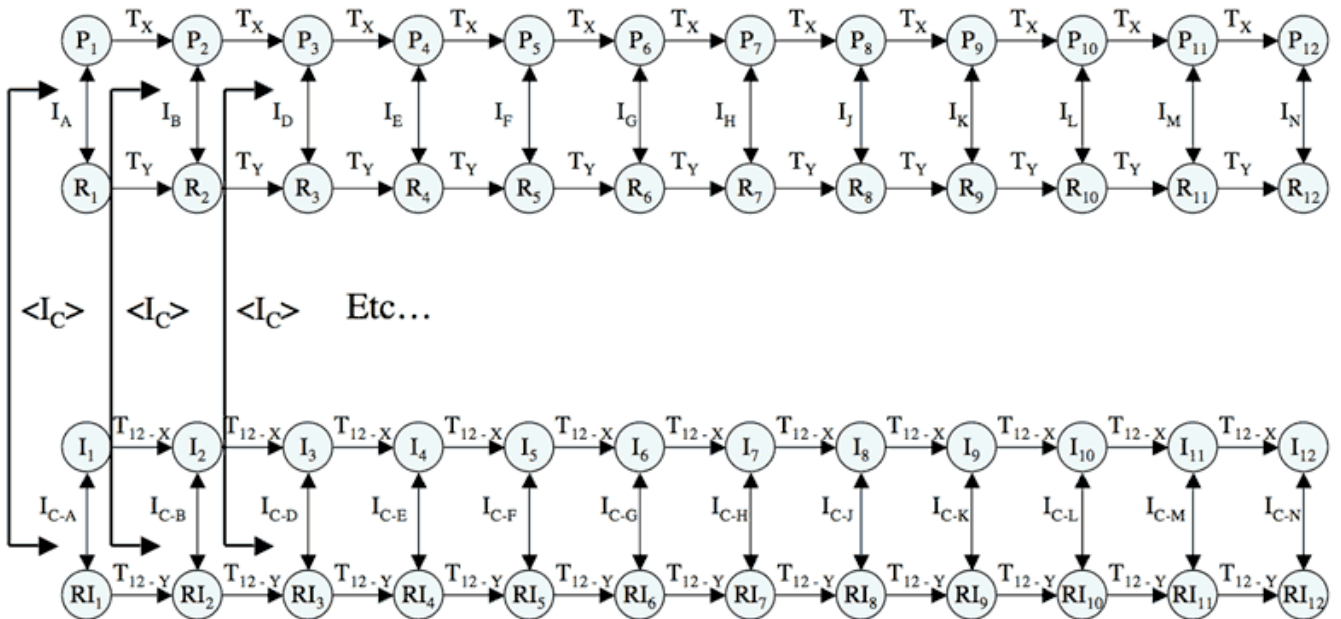

Figure 3. An invariant, negative isogrophy relationship holds between P&R, I&RI row-form pairs



Example 1. Paired duets in Webern, *Das Augenlicht*, mm. 8–13; 14–19

Tempo, ruhig poco rit.

P₈ S
 6 *p* Durch uns - re off - nen Au - gen fließt das Licht ins Herz

R₈ T
 8 *p* Durch uns - re off - nen Au - gen fließt das Licht ins Herz

Tempo

I₈ A
 14 *p* und strömt als Freu - de sanft zu - rück aus ih - nen. *pp*

RI₈ B
p und strömt als Freu - de sanft zu - rück aus ih - nen. *pp*

Example 2. I-R analysis of the paired duets in Webern, *Das Augenlicht*, mm. 8–13; 14–19

P₈ S
 6 3 (R~) 2 (P-) 3 R-
 Durch uns - re off - nen Au - gen fließt das Licht ins Herz

R₈ T
 8 2 (R~) 4 R- 3 (R~)
 Durch uns - re off - nen Au - gen fließt das Licht ins Herz

Example 3. K-nets show harmonic relationships between corresponding melodic I-R structures in the paired duets from Webern, *Das Augenlicht*, mm. 8–13; 14–19

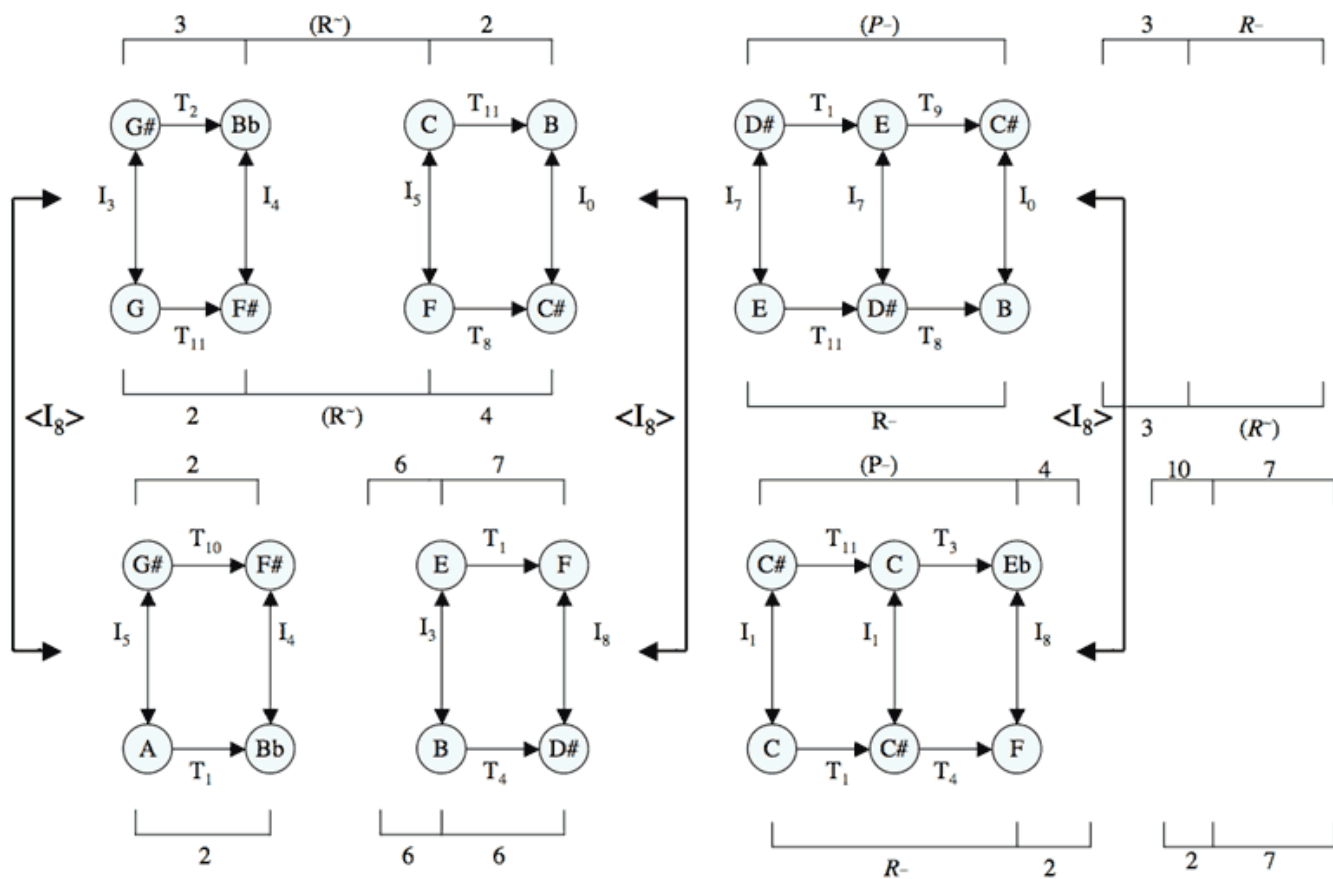

Example 4. <I8> describes the harmonic relationships between corresponding melodic I-R structures in the paired duets from Webern, *Das Augenlicht*, mm. 8–13; 14–19

The image displays a musical score for Webern's *Das Augenlicht*, focusing on the harmonic relationships between corresponding melodic I-R structures in two paired duets. The score is divided into two systems, each with a Soprano (S) and Tenor (T) part, and a second system with Alto (A) and Bass (B) parts.

System 1 (mm. 8-13):

- Soprano (S):** Melodic phrases are grouped with brackets and labeled with numbers and Roman numerals: 3 (R~), 2, (P-), 3, and R-.
- Tenor (T):** Melodic phrases are grouped with brackets and labeled with numbers and Roman numerals: 2 (R~), 4, R-, and 3 (R~).
- Harmonic Relationships:** Three <I8> symbols with arrows indicate the relationship between corresponding melodic phrases in the S and T parts.

System 2 (mm. 14-19):

- Alto (A):** Melodic phrases are grouped with brackets and labeled with numbers and Roman numerals: 2, 6, 7, (P-), 4, 10, and 7.
- Bass (B):** Melodic phrases are grouped with brackets and labeled with numbers and Roman numerals: 2, 6, 6, R-, 2, 2, and 7.

The lyrics for the Soprano and Tenor parts are: "Durch uns - re off - nen Au - gen fließt das Licht ins Herz". The lyrics for the Alto and Bass parts are: "und strömt als Freu - de sanft zu - rück aus ih - nen."